

**Optimizing
automation
for positioning
applications**

POSITIONING

Technology and experience you can rely on

A partnership
you can trust



Open system architecture

Future-proofing your automation is essential to competitiveness in a rapidly changing environment. Lenze understands that maximizing compatibility in the automation ecosystem is critical for maintaining costs, implementing the best technology solutions, and gaining a competitive edge. Our compliance with market standards and open platform allows for the efficient integration of components from various partners.

Customer-centric approach

Our top priority is collaborating closely with you as a partner, not just a product manufacturer. Automation can be complex; therefore, we aim to turn your challenges into scalable solutions that stand the test of time. Whether enhancing existing equipment or designing new machinery, we're committed to setting your ideas in motion.

With over 75 years of experience optimizing automation, Lenze's mission is to deliver engineering resources and innovative products at every stage of your automation and positioning ecosystem, ensuring your success is our success. From initial planning to final equipment commissioning, your success is not just a goal but the very measure of our partnership in progress.



Hardware and software working in tandem for positioning applications



Drives

- i950 cabinet servo drive
- i750 cabinet multi-axis servo drive
- i550 cabinet variable frequency drive

Motors

- MCS
- m550
- MF
- m850

Software

- Lenze FAST application software toolbox
- EASY Starter

Common positioning application areas

- Pick and place
- Traverse and electronic gearing
- Lift and conveyor
- Inserting and packagaing
- Stacker crane

The Lenze automation platform — optimized for compatibility

The Lenze automation ecosystem delivers high-quality, reliable products for various applications, from control level to mechatronics. Moreover, our commitment to sustainable manufacturing processes and energy efficiency is reflected in our vision to lead the industry toward a better future-built automation environment.

Additionally, we are committed to an open development platform that allows customers to choose the best products for their automation challenges, which is reflected in our partners' easy integration of Lenze components.

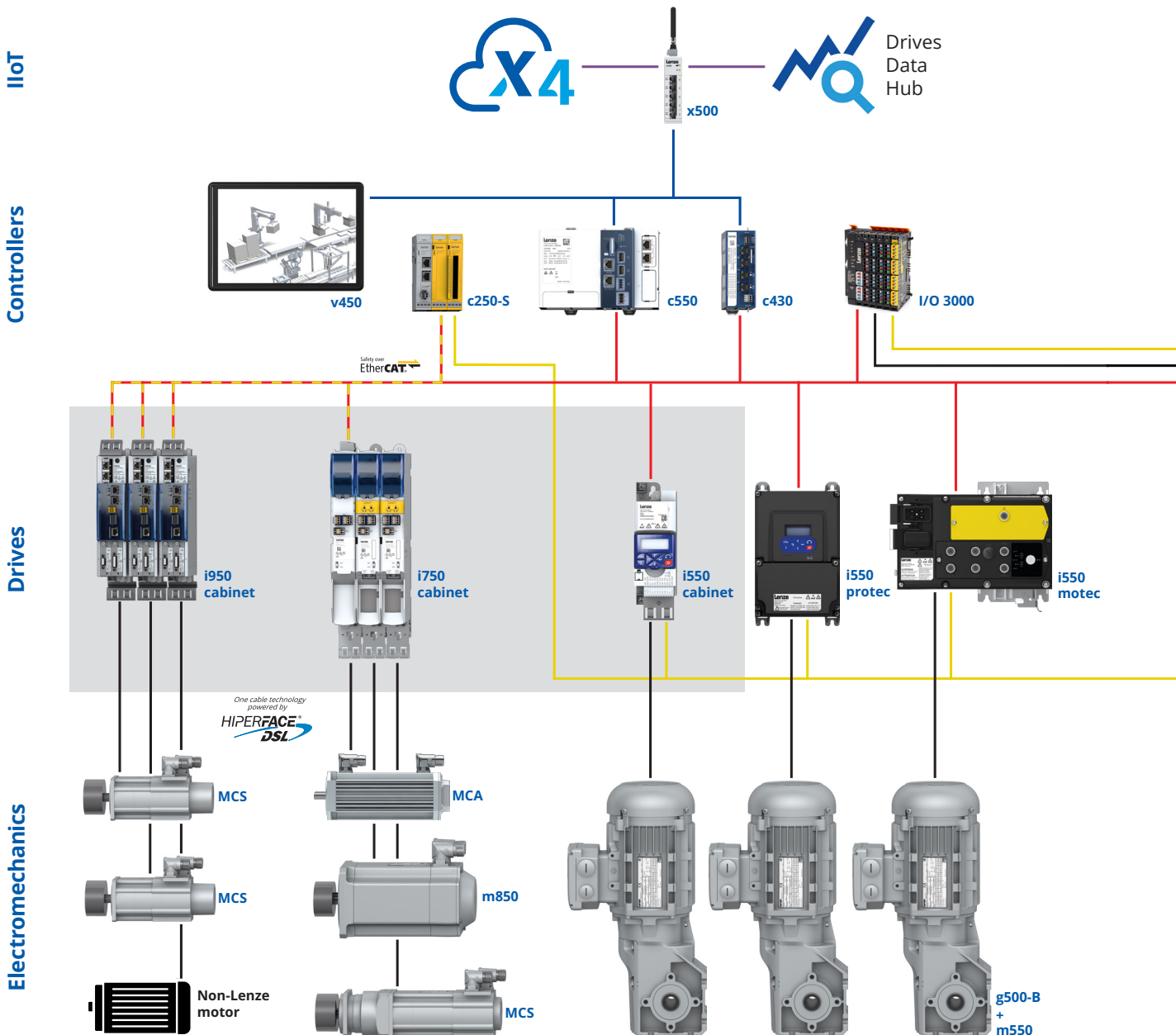

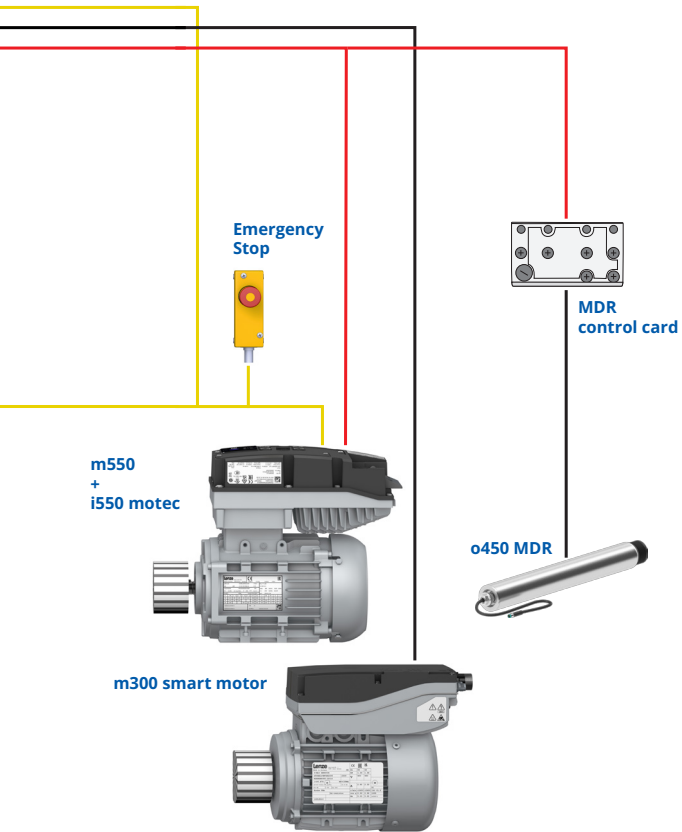
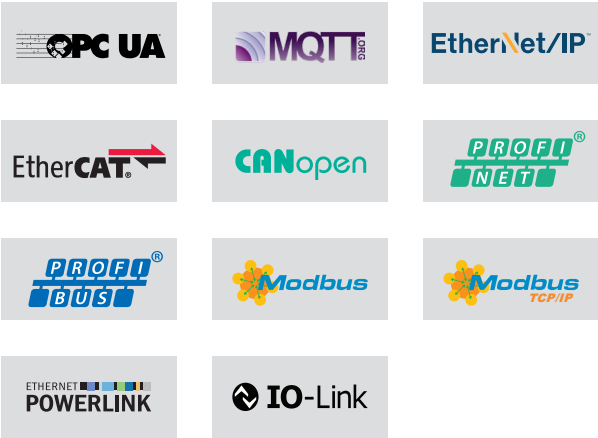

Drives — benefits, technology and safety options



i950 cabinet servo drive

- A reliable, integrated servo drive with PLC and I/O onboard
- Reduces engineering effort and cost
- Minimized footprint in control cabinets
- Auto-tuning function for quick and easy controller adjustment
- Reliable One Cable Technology (OCT)
- Simplified integration and programming utilizing Lenze FAST application software toolbox
- Integrated safety protocols

The intelligent i950 cabinet servo drive offers advantages where high accuracy is needed.

Experience seamless integration within modular systems. Designed with ready-to-use technology applications, we prioritize your convenience. Enjoy the simplicity of parameterization, eliminating the need for complex programming.



[Specification sheet](#)



i750 cabinet multi-axis servo drive

- Single or double-axes capable
- Narrow profile (50mm), ideal for double-axes
- Auto-tuning function for quick and easy controller adjustment
- Reliable One Cable Technology (OCT)
- Easily programmable using Lenze FAST application software toolbox

The i750 cabinet multi-axis servo drive provides everything for precise and dynamic motion control in complex multi-axis applications.

Advanced safety functions and One Cable Technology reduce wiring and control complexity while intelligent data-based functions and IIoT enable innovative motion control concepts.



[Specification sheet](#)



i550 cabinet variable frequency drive

- Budget friendly
- Compact size for installation in any cabinet
- Works well with all fieldbuses

The i550 cabinet variable frequency drive is a compact control cabinet device with scalable functionality. It is versatile, reliable, and easy to use.

For the greatest possible flexibility available as a complete device or in individual parts (Power Unit, Control Unit and Safety Unit).



[Specification sheet](#)

Servo drives

i950 cabinet | i750 cabinet

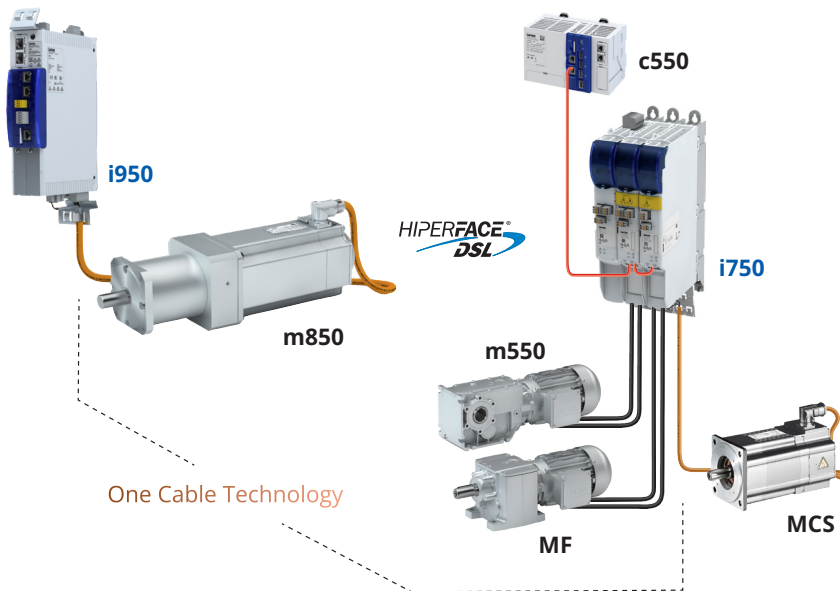

Featured technology

- Integrated safety with basic Safe Torque Off (STO) or extended safety
- Feedback options
 - Resolver
 - SinCos incremental encoder 1 Vss
 - SinCos absolute value encoder 1
- Vss with HIPERFACE®
 - EnDat 2.1/2.2
 - HTL via I/O extension module (i950 only)

One-Cable Technology

On the i950 and i750, connecting cables, cable variance and connection costs are minimized through the use of future-oriented One Cable Technology (OCT), a hybrid cable merging power and encoder data by way of the open motor feedback protocol HIPERFACE DSL®.

HIPERFACE DSL® is characterized by increased noise immunity and efficient detection and elimination of interference.

Extended safety options

- Profisafe
- FSoE via Systembus
- Safe stop 1 (SS1)
- Safe stop 2 (SS2)
- Safe operating stop (SOS)
- Safely limited speed (SLS)
- Safe maximum speed (SMS)
- Safely limited increment (SLI)
- Safe direction (SDI)
- Operation mode switch (OMS with enable switch (ES)
- Pos. depended safe speed (PDSS)
- Safe in and outputs
- SBC
- Muting

Variable frequency drive

i550 cabinet



Featured technology

- Integrated safety with Basic Safe Torque Off (STO)
- Motor feedback via HTL encoder
- Easily programmable using Lenze FAST application software toolbox

Application product guide.

Various kinematics for numerous applications.

Pick and place

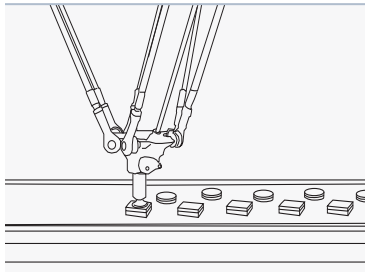

- Linear Systems - for extended or heavy duty applications
- Delta - for highly dynamic solutions
- SCARA - for rapid and precise handling
- Belts - as a universal system
- Joints - for typical palletizing applications

Traverse and electronic gearing

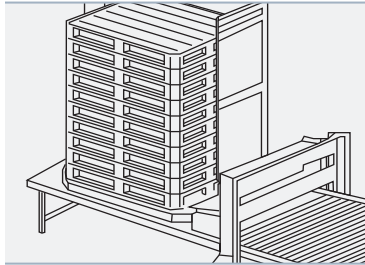

- For simple positioning of an axis to complex, coordinated multi-axis applications
- Electronic cam, electrical shaft, and virtual master for precise axis movements
- Material-independent winding - with dancer controller
- Cross cutters and flying saws for cutting

Lift and conveyor

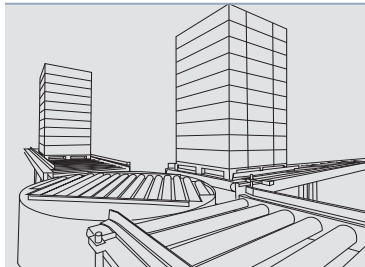

- Flexible decentralized or panel-based drive solution for horizontal handling systems
- High degree of reliability
- Reduced energy consumption
- Soft-starting and braking with adjustable ramps
- Simplified wiring complexity for more efficient installation

Inserting and packaging

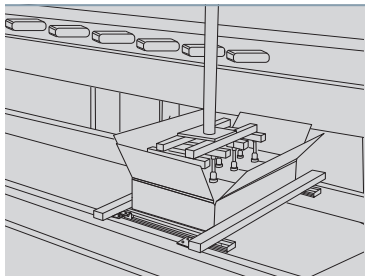

- Outstanding reliability due to low-wear brake management
- Reduced stress with load held in position at standstill
- Simplified and expedient replacement during maintenance
- Reduced energy consumption due to power recovery

Stacker crane

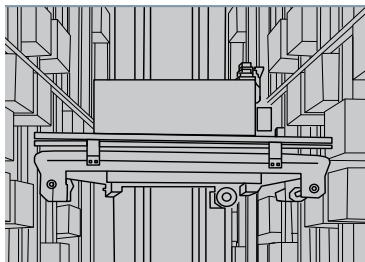

- Advanced storage and retrieval units
- Simplified commissioning
- Increased storage capacity
- Optimized motion control leads to reduced energy consumption
- Regenerative modules recapture energy

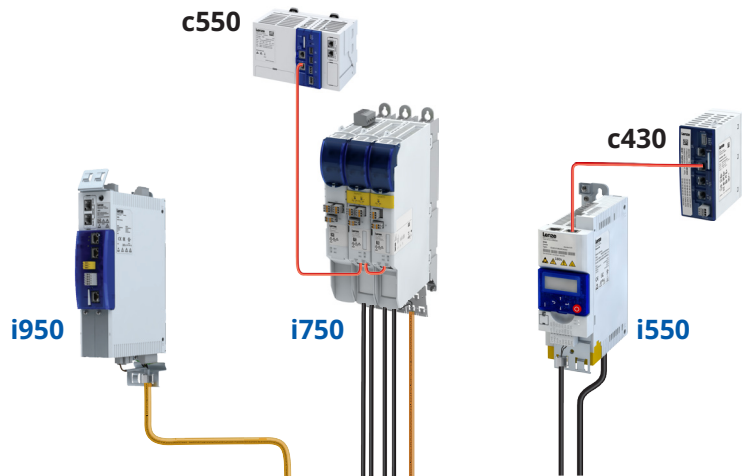

	Typical machine values					
	Accuracy in. (mm)	Accuracy in. (mm)	Mass lbs (kg)	Speed ft/s (m/s)	Acceleration ft/s ² (m/s ²)	Power hp (kW)
Pick and place	0.002" ... 0.039" (0.05 ... 1)	----	11 ... 220 (5 ... 100)	3.28 ... 32.8 (1 ... 10)	65.6 ... 98.4 (20 ... 30)	0.75 ... 0.14 (0.55 ... 10)
Traverse and electronic gearing	0.004" ... 0.039" (0.1 ... 1)	0.020" ... 0.394" (5 ... 10)	4,409 ... 13,228 (2,000 ... 6,000)	9.84 ... 19.7 (3 ... 6)	6.56 ... 9.84 (2 ... 3)	0.14 ... 75 (10 ... 55)
Lift and conveyor	0.004" ... 0.079" (0.1 ... 2)	0.020" ... 0.394" (5 ... 10)	11,023 ... 17,636 (5,000 ... 8,000)	1.64 ... 3.28 (0.5 ... 1)	1.64 ... 4.9 (0.5 ... 1.5)	40 ... 136 (30 ... 100)
Inserting and packaging	0.004" ... 0.079" (0.1 ... 2)	----	220 ... 1,102 (100 ... 500)	3.28 ... 32.8 (1 ... 10)	3.28 ... 26.2 (1 ... 8)	3... 95 (2 ... 70)
Stacker crane	0.020" ... 0.079" (0.5 ... 2)	----	220 ... 55,116 (100 ... 25,000)	3.28 ... 19.7 (1 ... 6)	1.64 ... 16.4 (0.5 ... 5)	10 - 75 (7.5 - 55)

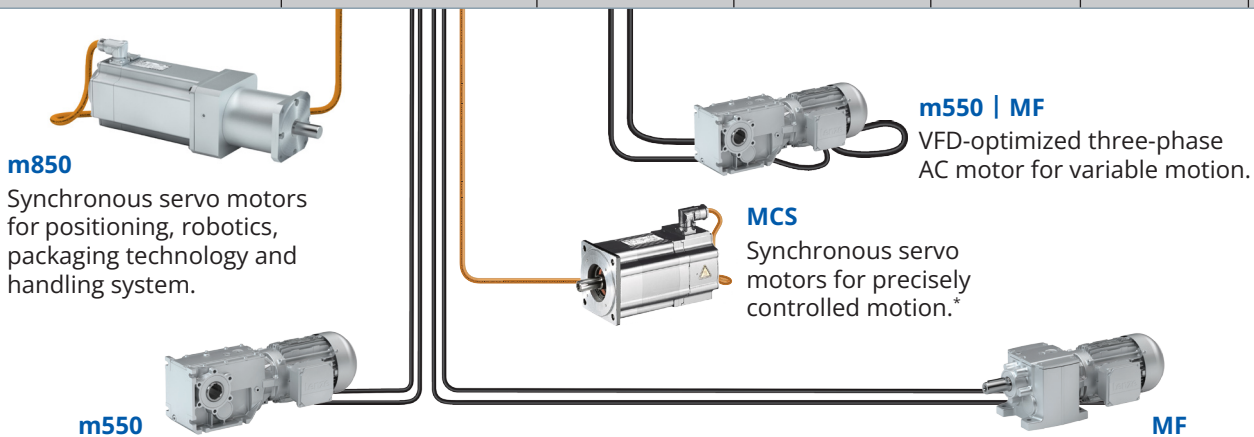

*Various combinations with induction and servo motors are possible.

EASY Starter software — quickly parameterize, commission, and diagnose

EASY Starter supports service technicians with the commissioning and maintenance of your machines thanks to easy-to-use diagnostic and parameterization dialogs.



Ready-to-use software engineering modules for i950 cabinet and i750 cabinet

Lenze FAST application software toolbox, allows you to implement up to 80% of complex motion tasks utilizing pre-programmed functionality into your machine.



Modular software architecture

With the Lenze FAST application software toolbox, you achieve modularization of machine functions and standardization of interfaces, which ultimately reduces the time, cost and complexity of software engineering.

Costs and complexity under control

Pre-tested, documented and reusable software modules lead to improved quality and optimized resource management. This means you can easily reuse, expand and maintain software modules — efficiently, reliably, and safely.

In addition, standards such as PLCopen ensure the openness of our Lenze system.



Positioning module



Features

- Sequenced time or event controlled motion profile positioning function
- 15 positioning profiles
- TouchProbe positioning (registration)
- Profile linkage with velocity changeover
- Teach function
- Override for velocity, acceleration and jerk
- Homing
- Manual jog
- Software + Hardware limit switches
- Torque limitation
- Output of electric shaft (e.g. follower)



Lenze FAST
Overview Video

Lenze
engineered to win

©Copyright 2024 Lenze Americas Corporation
LAM-0036BR · US · 08.2024

(800) 217-9100
info.us@lenze.com

Lenze Americas
630 Douglas St.
Uxbridge, MA
01569

lenze.com