

HVAC-R

**Air condition  
applications –  
optimally solved with  
Lenze inverters**





# Lenze inverters for your HVAC-R applications

Lenze can offer the right solution for all of your applications. The scaled **i-series inverter** range, coupled with Lenze's application expertise, overcomes the challenges of increasing demands for energy efficiency, space constraints, a lack of skilled staff, and changing customer requirements.

## Typical applications

- Industrial refrigeration
- Heat & steam generation
- Ventilation technology
- Filtration systems
- Hot and cold water pumps
- Vacuum pumps
- Air compressors

Optimally solve **air conditioning applications** with the **Lenze i-series (cabinet, protec, and motec)**.



### Flexibility

Lenze has the ideal solution for every environment whether for the control cabinet or decentralized installation sites. Choose between price or function optimization, with optional safety technology and all market relevant fieldbuses.

### Energy efficiency

Lenze inverters satisfy the European Ecodesign Directive and achieve the lowest energy losses in an industry-wide comparison. Lenze guarantees long-term planning reliability.

### Compact size

Save costs with the smallest inverters in the series that take up minimal space in the control cabinet: Space saving design of 60 mm | 2.36 in wide (up to 4 kW | 5.0 hp) and 130 mm | 5.12 in deep (up to 11 kW | 15 hp) with zero-clearance mounting.

### Easiest handling

Our frequency inverters ensure easy handling and greatly reduced installation, commissioning, and service times. Expect:





- programming without mains power
- easy menu navigation
- practical default settings
- pluggable terminals, and more.









## Content

Inverter portfolio	2
Fans, dust extractors, blowers & side channel blowers	4
Refrigeration & heat pumps	6
Hot and cold water pumps, oil pumps	8
Vacuum pumps	10
Air compressors	12
Worldwide service	14



### Our i-series solution space from 0.25 to 132 kW (0.33 to 180 hp)

i510 cabinet i550 cabinet	i510 protec (for UL installations)	i550 protec	i550 motec
			
Lowest investment costs for inverters	Cubic design for control cabinet	Save the costs of motor cables and control cabinets	NEMA 4X/IP66 wall or motor mounting
Lowest space requirement for control cabinet	Compact and economical for decentralized installations in accordance with NEMA Type 1	The most compact NEMA 4X/IP66 inverter allows for operation in rough environments	High vibration resistance
For installation outside critical environments (e.g. ATEX)		Optional service/disconnect switch for safe servicing	Highest power factor of 0.95
			Fast braking without brake resistor
			Easiest installation





# Fans, dust extractors, blowers & side channel blowers

These products ensure dust-free surfaces, cool, warm or particle-free air, and can create vacuums or convey light bulk materials. Lenze frequency inverters provide the answer to the constantly increasing demand for process performance, modularization, system intelligence and energy efficiency.

## Typical applications

- Material processing
- Food technology
- Plastics technology

Picking the right inverter depends on your operating conditions and customer preferences. Important influencing factors include the installation site (in the control cabinet or field mounted), the type of desired control and the environment, since commercial and industrial settings require different electromagnetic compatibility and leakage current requirements.

The i-series has proven to be **successful in the market** due to its compactness, simplicity, and good **price-performance ratio**.



**Lenze frequency inverters have proven themselves in this market with the following features:**

- The devices are extremely easy to handle which helps you optimize costs in series business
- Flexible control via a keypad, IOs with integrated PID controller, potentiometer or fieldbuses
- One family of drives for decentralized installation, installation in a control cabinet, or direct installation on the motor
- Multiple fans can also provide an economical alternative to EC fans
- The i550 protec with optional extension box for flexible customer installation of components, e.g. control elements, 24V supply, emergency-off circuit
- Robust motor control allows the use of standard and high-speed motors with rated speeds from 50 – 87.5 Hz or up to 300 Hz and more, to make your fan both compact and economical
- Integrated EMC filter C2 typically up to 20 m (65.6 ft). Optional footprint filters are available for higher requirements
- 30mA RCD operation up to 45 kW (60 hp) for use in first environment (small businesses, residential areas), depending on the configuration
- Saving of braking resistances through regenerative braking (i550 motec)

**Compact and robust**

The fan is controlled with an **i550 protec with an optional extension box** with service/disconnect switch in **IP66/NEMA 4X**. Thanks to the switch, the fan can be cleaned and serviced easily and safely.

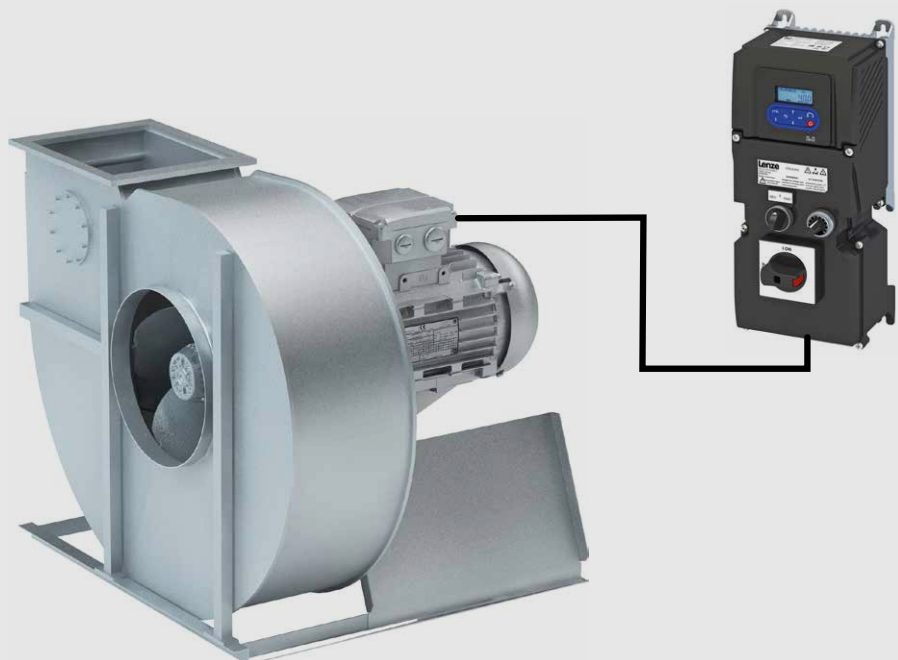



# Refrigeration engineering and heat pumps

Frequency inverter controlled compressors play an attractive role in the market, alongside the increased demand for high performance, energy efficiency, and environmentally friendly specifications (e.g. for natural refrigerants).

This applies to all types of compressors, such as rotary compressors, scroll compressors, reciprocating compressors. The use of speed-controlled pumps and fans is also steadily increasing in order to preserve resources.

## Typical applications

- Industrial cooling
- Medical technology
- Machine tools
- Building technology

Due to its **compact design**, the i-series needs **significantly less space** than comparable solutions.



**Lenze frequency inverters have proven themselves in this market with the following features:**

- Energy efficiency - the i-series achieves the lowest energy losses
- Higher motor frequency (50 ... 80 Hz) leads to an increase in output power with same-sized compressors as compared to direct-on-line operation
- Easy programming without mains power via USB
- BLDC motor operation support
- Integrated, easy-to-use and powerful PID controller for the vacuum
- Lower control cabinet costs with the most compact inverter and integrated EMC filter. Also applicable for decentralized installation
- Optional integrated STO module in the i550 as protection against hot gas overpressure
- Function as a smart sensor and transfers valuable data for current values, operational cycles etc. via a fieldbus interface to the control system (PLC)

**Communicative and safe**

The compact **i550 cabinet** (here 11 kW (15 hp)) permits the connection of all necessary fieldbuses with supportive **PLC integration material**. The optional integrated **STO functionality** offers protection against overpressure in the cooling circuit.

Further applications in refrigeration technology for pumps and fans can be solved in the same way with the cost-optimized i510 cabinet inverter.

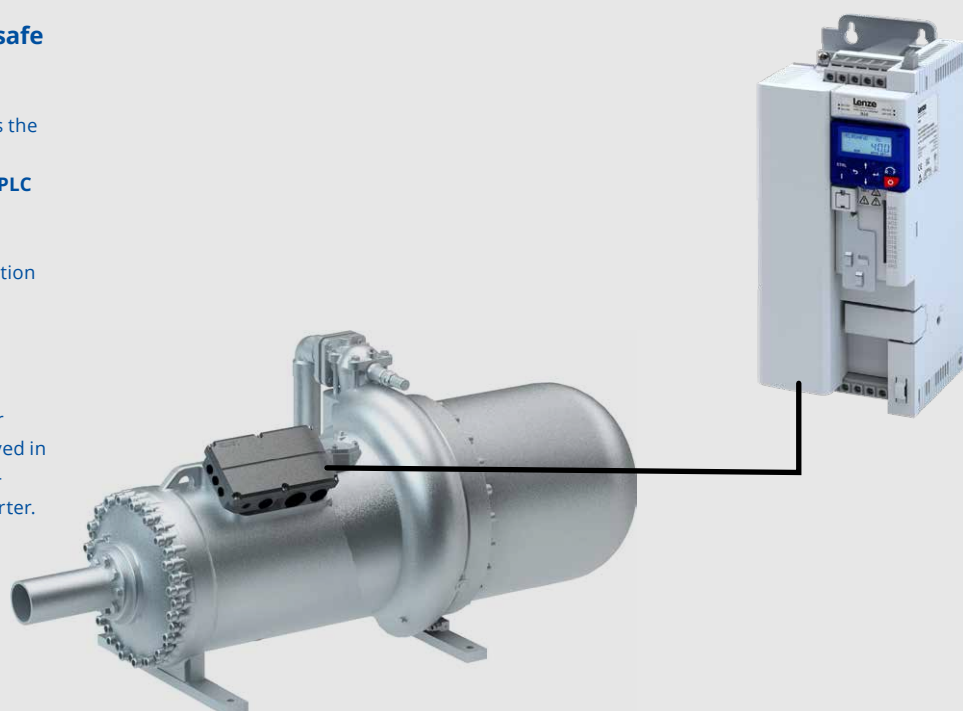



# Hot and cold water pumps, oil pumps

Demand for speed-controlled pumps in industry and commerce is increasing.

The pumps can be easily controlled via a keyboard, analog signals, or optionally all fieldbus communication protocols.

## Typical applications

- Cooling and heating pumps
- Temperature control units
- Oil pumps

Thanks to their flexibility, the i500 series of inverters offers excellent design space for mechanical engineers confronted with dynamic requirements. The compact design, easy operation, and high energy efficiency make our inverters the first choice for temperature controller customers.

In temperature-critical applications, the **i-series** is **exceptionally efficient** by industry standards and **increases the energy efficiency** of the plant.

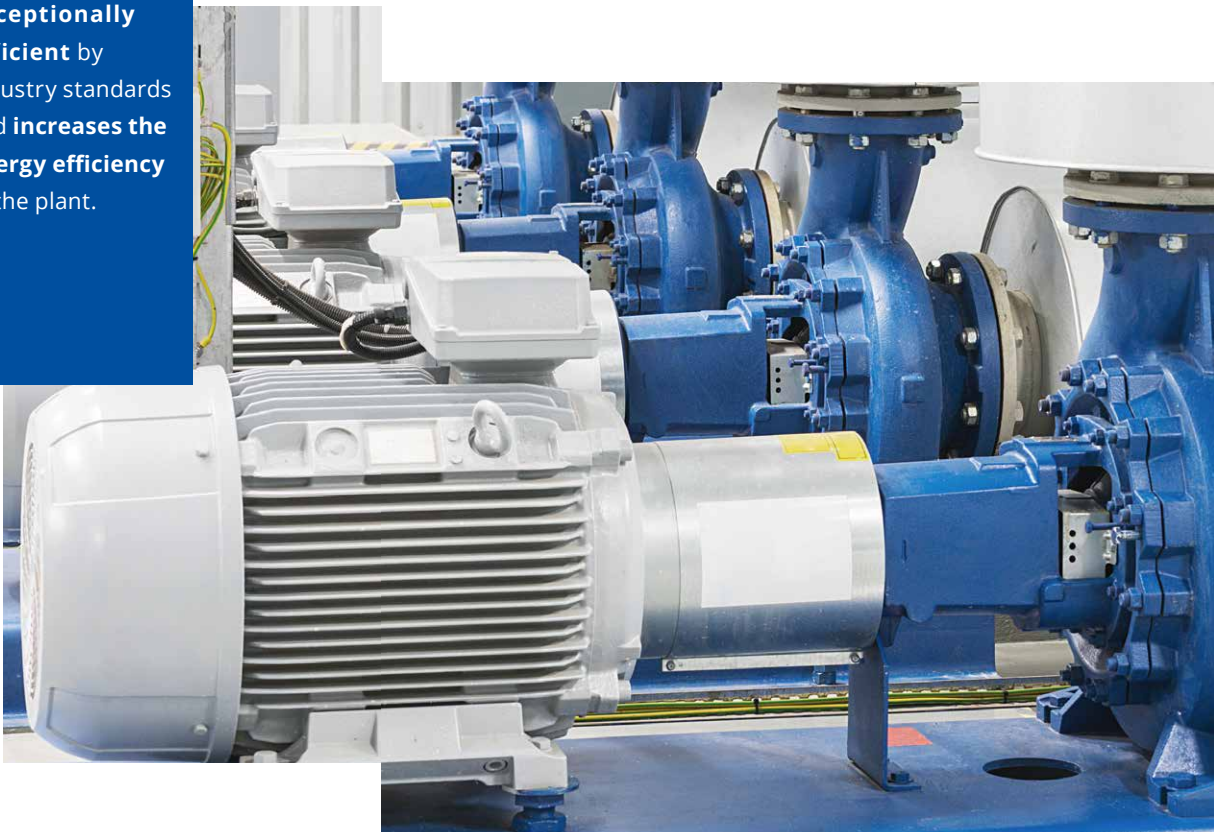



**Lenze frequency inverters have proven themselves in this market with the following features:**

- High efficiency e.g. temperature controllers with > 25% energy savings
- Fewer variants – one global solution, e.g. one inverter for 400 V (50 Hz) or 480 V (60 Hz)
- Less engineering effort: just one hydro-mechanical design, irrespective of local mains voltage

- Process stability, despite contamination of particles on the pump/piping
- Savings on external components, since our inverters collect and supply a lot of data and offer various parameterizable functions such as reversible rotational direction

**Market proven technology**

Apart from stepless speed control, the i550 can also take over various control and monitoring tasks and therefore save PLC performance. The integrated PID controller can control the flow, temperature or pressure through the analog input of the respective sensor.

The inverters offer a sleep and rinse function or cascaded pump control. The robust motor control is compatible with economical asynchronous motors or efficient and compact permanent magnet synchronous motors.



**Quickly installed**

This pump is controlled with the i550 motec, which offers a **variety of potential savings** for our customers: maximum efficiency, fast installation time thanks to plug technology, no need for expensive motor cables, and **easy commissioning via RFID or USB**. A drive package consisting of a Lenze motor and inverter further facilitates handling, especially with the compact 120-Hz MF motor.

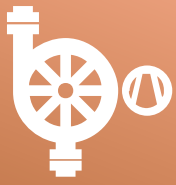

# Vacuum pumps

Vacuum pumps generate vacuum, suck off air from surfaces, and convey light bulk material. Rising demands for smart interaction with control systems, precise and service-friendly controllers, and system efficiency have all lead to the increasing use of speed-controlled vacuum pumps.

## Typical applications

- Packaging industry
- Food industry
- Plastics industry
- Electronics and semiconductor manufacturing

Vacuum pumps are often only equipped with a frequency inverter during their final installation. In order to simplify matters and achieve better performance, more and more vacuum pump manufacturers are offering their own modules with integrated inverters.

## Cabinet, protec and motec –

All three versions are identical in terms of handling and commissioning.



**Lenze frequency inverters have proven themselves in this market with the following features:**

- Highest energy efficiency in the market
- Economical machine design due to the robust motor controller for ASM and PM motors with higher motor frequency (50...300 Hz)
- Flexible setpoint selection: independent PID control, various fieldbuses or local manual operation via keypad or potentiometer possible
- Lower costs from first-class serial commissioning features and service
- Optimized solution for every application and cost requirement with identical user interfaces and drive behavior:
  - **i550 motec**, IP66/NEMA 4X for motor or wall mounting
  - **i550 protec**, IP66/NEMA 4X for wall mounting or mounting frame
  - **i550 cabinet** for particularly sensitive applications
- Voltages (1 ph/110V to 3 ph/600 V)
- Power ratings 0.25 to 132 kW (0.33 to 180 hp) and fieldbuses

**Powerful and compact**

The i550 protec with 22 kW (30 hp) IP66/NEMA 4X drives this vacuum pump. Thanks to the **compact size** and light weight 10.1 kg (22.2 lbs), the protec can be easily installed on a mounting frame or decentralized on the wall. The **i550 protec is a very attractive solution** in this cost-sensitive market segment.

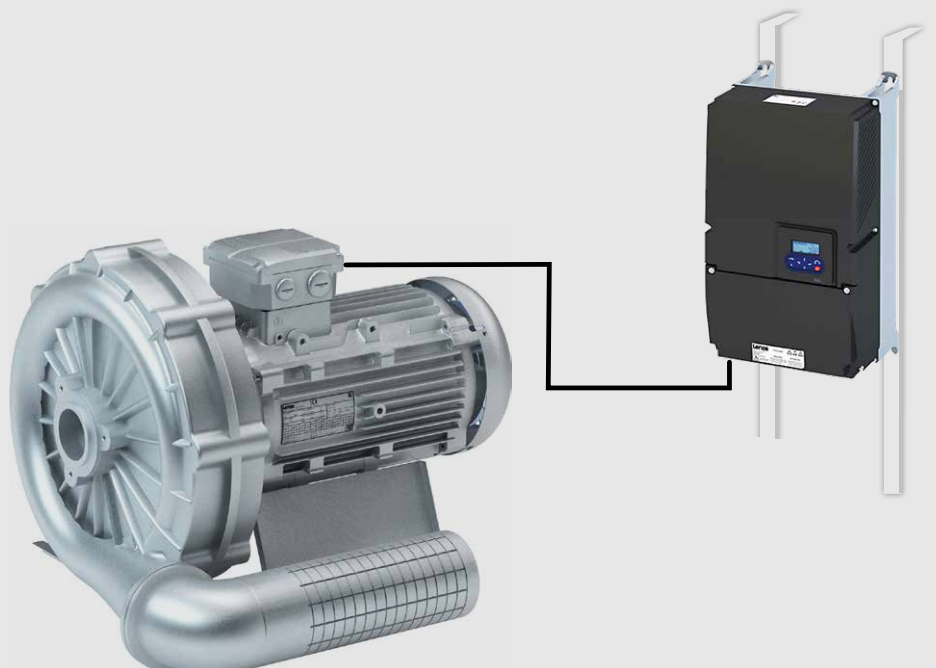



# Air compressors

The majority of these compressors are operated with an on-off switch without speed control. The demand for more precise processes in production, along with the wish for greater sustainability, have led to more and more systems being controlled by inverters with both asynchronous and synchronous motors.

The overall costs of the system are decisive when it comes to choosing the right drive technology. Costs are reduced if these functions are already integrated in the investment costs of the device and the handling costs can be kept low.

## Typical applications

- Packaging industry
- Food industry
- Plastics industry

Thanks to **integrated functionalities**, the i-series offers simple, fast and fail-safe handling.



**Lenze frequency inverters have proven themselves in this market with the following features:**

- Minimal energy losses in a targeted manner
- Asynchronous and permanent magnet motor control with higher motor frequency (50 ... 300 Hz). This leads to a more economical design of your machine
- The inverter acts as a sensor and transfers data to the control system (PLC)
- Integrated EMC filter and low leakage current for 30mA-FI operation for each configuration up to a max. of 45 kW (60 hp)
- The i550 motec has a robust decentralized IP66/NEMA 4X design with high vibration and shock resistance
- Optional fieldbus interfaces from Modbus RTU to PROFINET with predefined building blocks for easy and performant integration in the control system
- World's first IO-Link solution to integrate inverters via IO-Link master – a powerful, simple and cost-effective solution, if an IO-Link master is already available
- Optimized solutions for workshops with regard to EMC, harmonics and leakage current
- Lower costs with first-class serial commissioning and serviceability

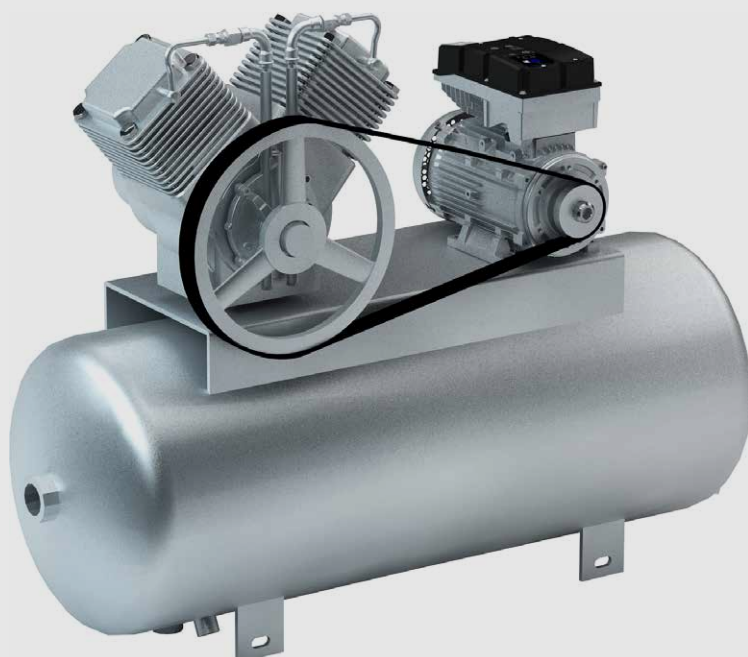

**Motor- or wall-mounted**

The variable speed control of the compressor is carried out via the wall-mounted **i550 motec** – or alternatively for motor mounting.

The **integrated IO-Link interface capability** (IO-Link sensors can be read directly), the pluggability and the easy interaction via smart phone (RFID/WLAN), or USB make its handling much easier.



## Worldwide services

**You can rely on every aspect of our high quality standards.**

Our service is designed to ensure the reliability of your machine and to guarantee its availability.

With proactive solutions that rule out any contingencies as far as possible and structured procedures that ensure the fast and smooth restoration of the machine's functions in an emergency.

A large number of our services can be used online at any time, or you can get personal help and advice from our specialists.



24/7 Lenze expert helpline

### **Online Support**

Here you can directly request support and repairs for specific Lenze products or order spare parts and call up technical data and documentation.

Simply enter the material number or scan the type plate with our integrated scan function. All support information is immediately available to you at a glance.

### **Replacement demands**

Are you using Lenze equipment and do you need to replace a complete device or some parts? We can send you a corresponding offer very quickly with our online service.

### **Original repairs from Lenze**

In some cases, the fast repair of a high-quality Lenze drive may be a good alternative in terms of quality and economics to replacing the complete product. This helps you minimize costly downtimes in cases of emergency and means that you don't have to keep large stocks of spare parts.

### **Maintenance with a plan**

So as to ensure maximum machine availability, our maintenance package includes additional services that proactively safeguard your operations. We analyze your requirements together and come up with customized concepts based on our many years of expertise in this field.



Original Repair

# Lenze

engineered to win

This document is the intellectual property of Lenze SE, Hameln (Germany). All data contained in this brochure correspond to the information available at the time of printing and are for preliminary information only. Possible color deviations from the original product are due to printing technology. Lenze is the sole and exclusive and exclusive owner of the copyright and ancillary copyright. Any use, in particular distribution, reprinting, exploitation and adaptation of this document is permitted only with the express written consent of Lenze.